

Very high clamping height
4 different models
Quick assembly

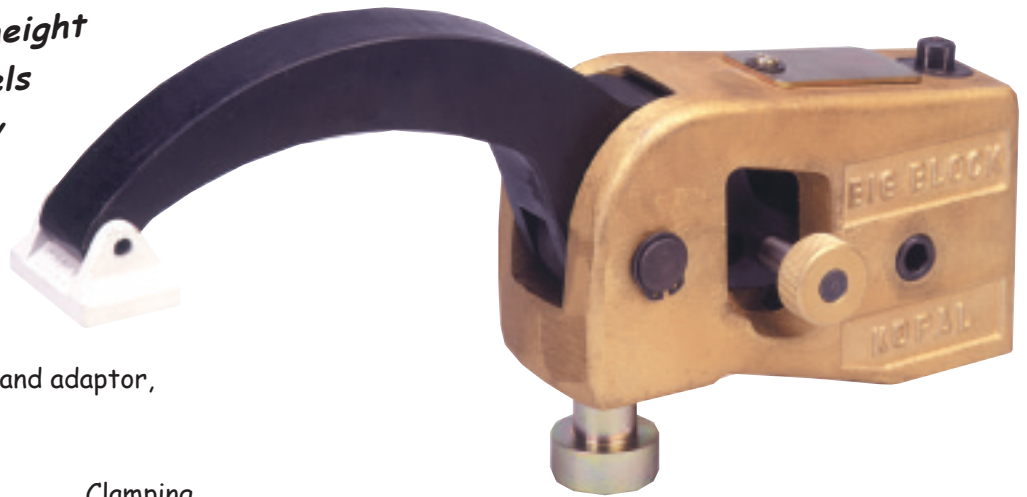

Clamp
With clamping key, swivel shoe and adaptor,
steel arm, aluminium body.

| Big Block | Clamping | Reach | Clamping Height | Torque | Ref. |
|-----------|----------|-------|-----------------|--------|--------|
| | 40000 N. | 50 | 12 to 80 mm | 70 N.m | 08-020 |
| | 28000 N. | 95 | - 12 to 100 mm | 70 N.m | 08-030 |
| | 20000 N. | 145 | - 18 to 135 mm | 70 N.m | 08-035 |
| | 14000 N. | 245 | - 50 to 155 mm | 70 N.m | 08-038 |

Clamping key

08-160

Use :
T-slot tables
Milling machines

i When the workpiece is released, the Big-block can either remain fixed in the slot, or slide in the slot.

Mounting directly on the table (without base or riser block), with a stud with cylinder (sold separately)

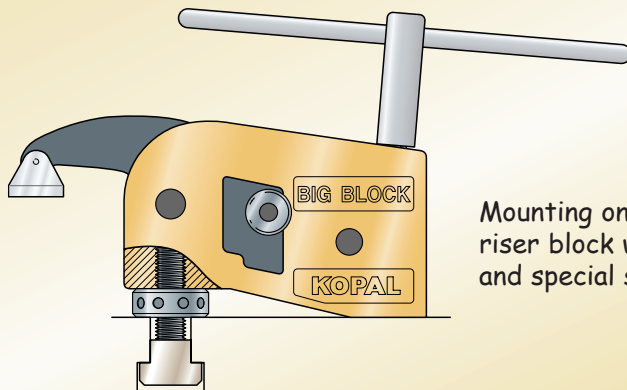

Quick mounting and dismounting

Mounting on base and riser block with adaptor and special stud

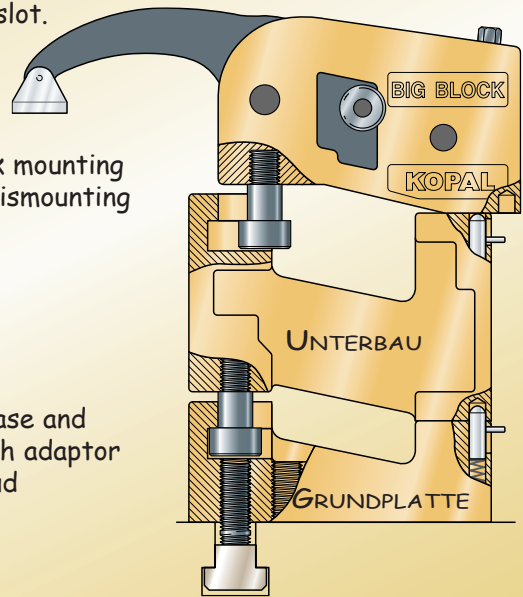

The arm can be indexed in 5 positions for quick clamping height adjustment.

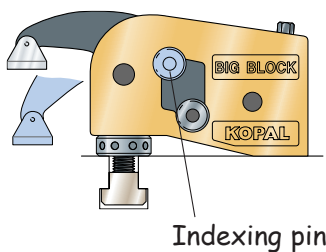

Indexing pin



KOPAL *BIG BLOCK* VERTICAL CLAMPING SYSTEM

Studs with cylinder

Ref.

For mounting the Big Block directly onto the table

| | | |
|-------|--------------|--------|
| V2-C1 | M 14 x 62 mm | 08-060 |
| V2-C1 | M 14 x 82 mm | 08-070 |
| V2-C2 | M 16 x 70 mm | 08-080 |
| V2-C2 | M 16 x 80 mm | 08-090 |

Special studs

For mounting the base on the table

| | | |
|------|--------------|--------|
| V2-1 | M 14 x 60 mm | 08-100 |
| V2-1 | M 14 x 80 mm | 08-110 |
| V2-2 | M 16 x 65 mm | 08-120 |
| V2-2 | M 16 x 85 mm | 08-130 |

| | | |
|-----------------|--------|--------|
| Riser block N°1 | 55 mm | 08-045 |
| Riser block N°2 | 110 mm | 08-050 |
| Riser block N°3 | 330 mm | 08-055 |

With an adaptor

55 mm aluminium base

With an M 16 x 65 mm mounting stud

08-040

Swivel shoes

| | |
|--------------------------|--------|
| Standard aluminium shoe | 08-330 |
| Wide shoe, steel, 100 mm | 08-210 |
| Wide shoe, steel, 130 mm | 08-215 |

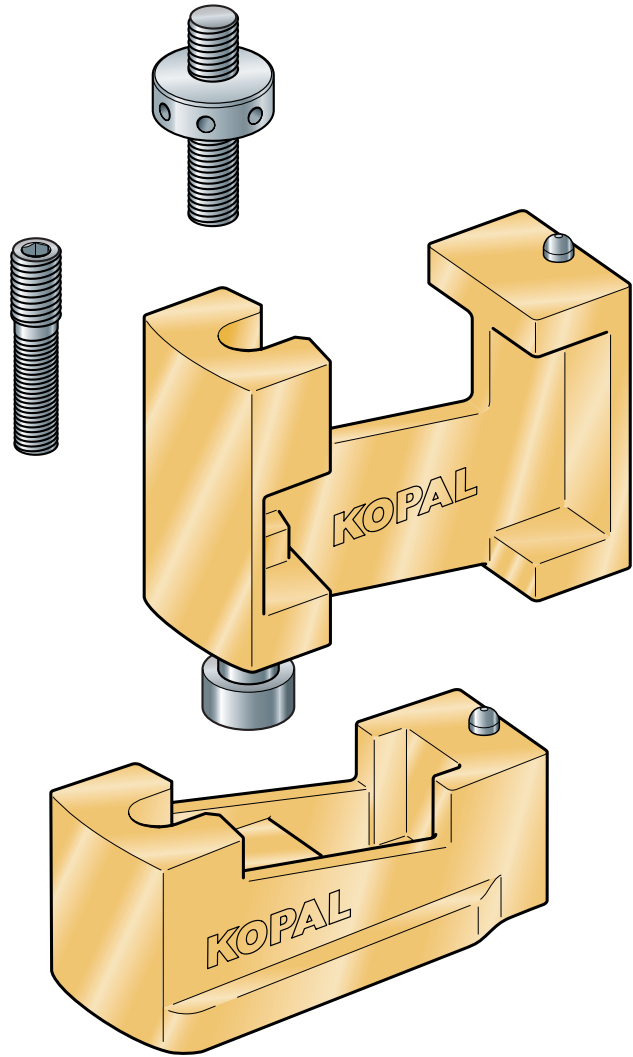

T-nuts for T-slots

| Slot size | M 14 | M 16 |
|-----------|--------|--------|
| | Ref. | Ref. |
| 16 mm | 90-200 | |
| 18 mm | 90-205 | 90-250 |
| 20 mm | 90-210 | 90-255 |
| 22 mm | 90-215 | 90-260 |
| 24 mm | 90-220 | 90-265 |
| 28 mm | 90-225 | 90-270 |

Sliding equipment

08-180

With bar, slide, adjustable workpiece support and 2 x M16 mounting screws

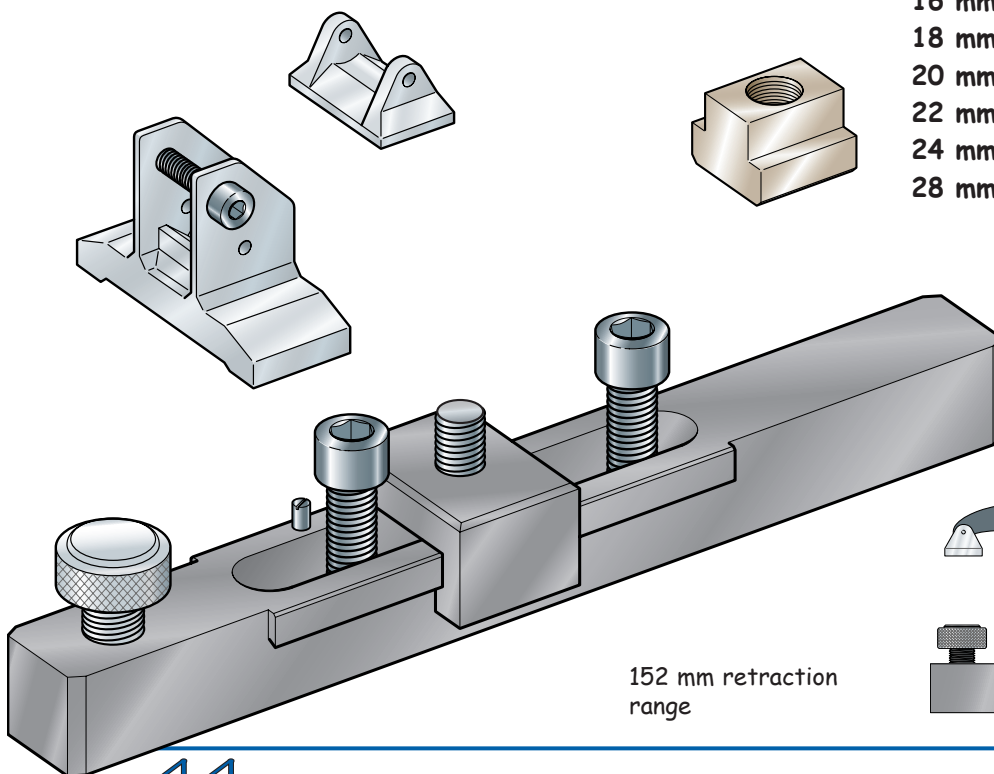

152 mm retraction range

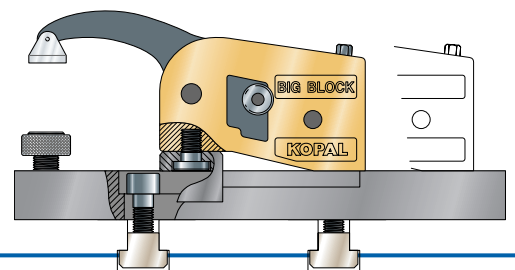

The range

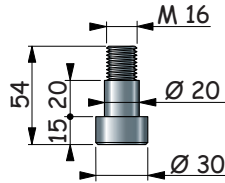
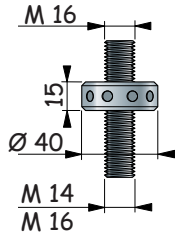
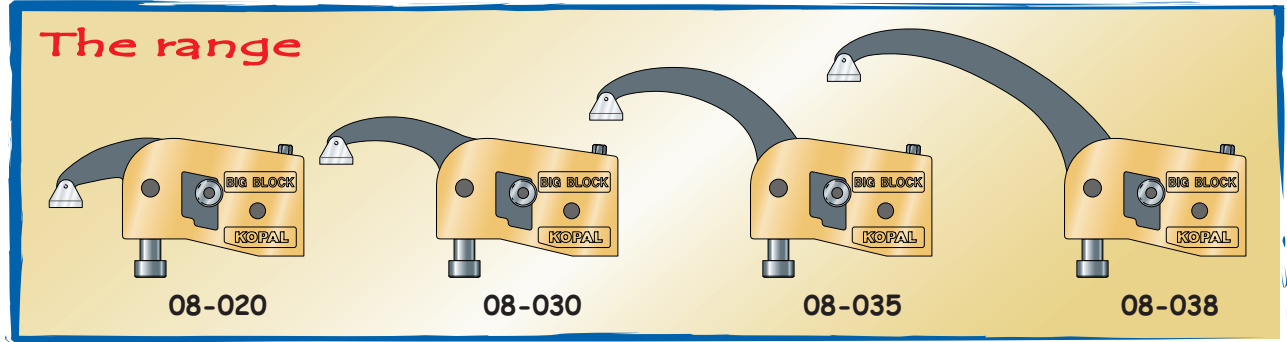

| Big Block | A | B | C |
|-----------|-----|------------|-------|
| 08-020 | 50 | 12 to 80 | R 75 |
| 08-030 | 95 | -12 to 100 | R 120 |
| 08-035 | 145 | -18 to 135 | R 170 |
| 08-038 | 245 | -50 to 155 | R 270 |

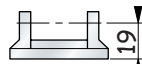
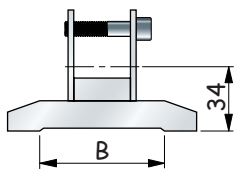
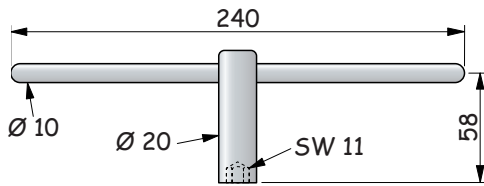
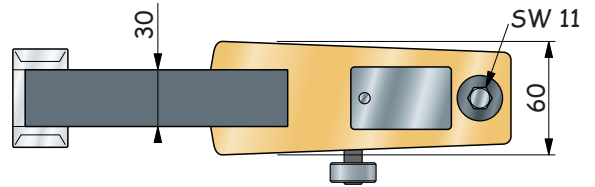
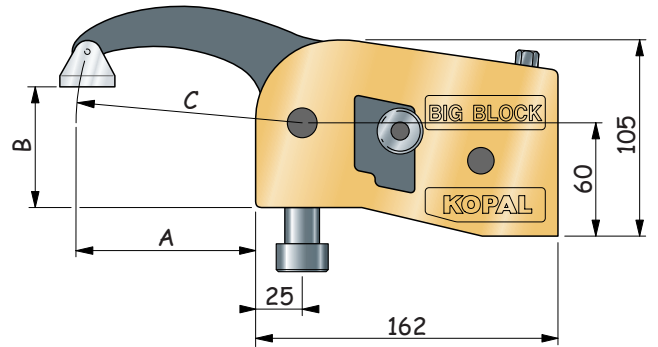

| Swivel shoes | A | B |
|--------------|-----|----|
| 08-330 | 52 | |
| 08-210 | 100 | 68 |
| 08-215 | 130 | 90 |

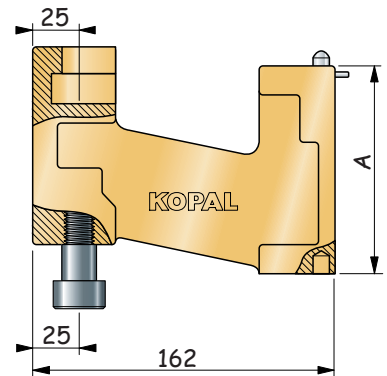
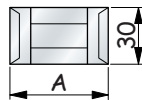
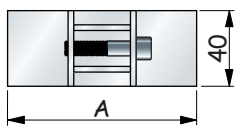

| Riser blocks | A |
|--------------|-----|
| 08-045 | 55 |
| 08-050 | 110 |
| 08-055 | 330 |

