

CHAIN CLAMPING

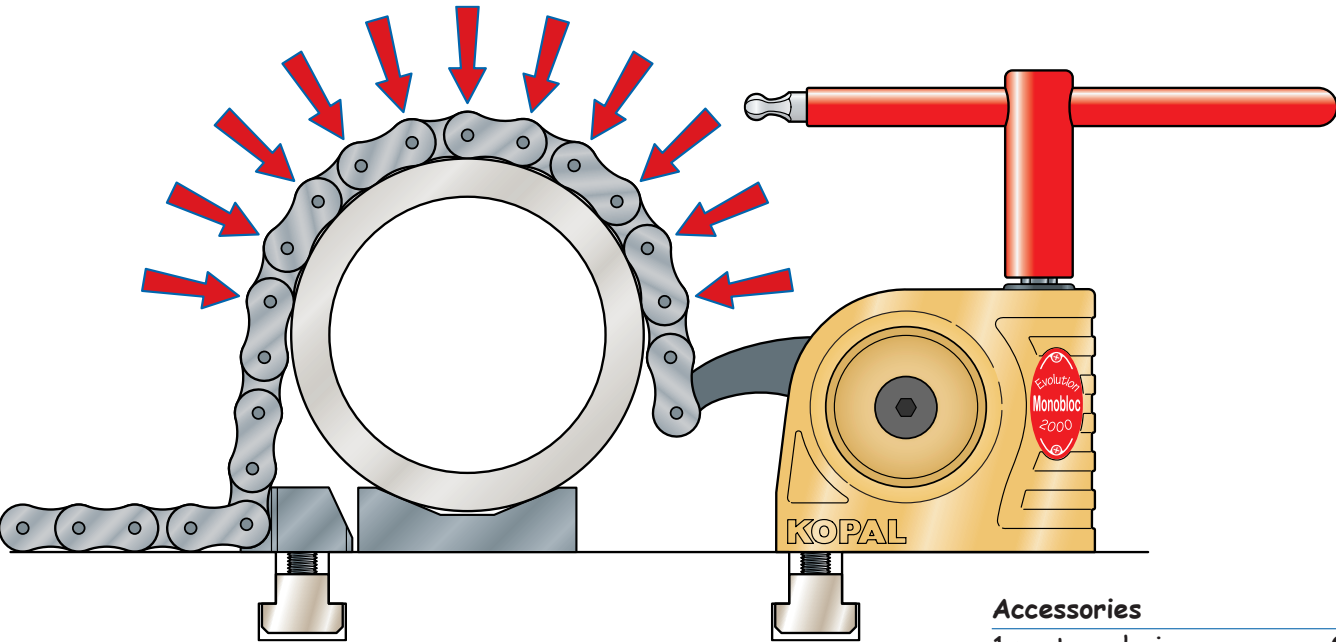

Even distribution of clamping force
 Quick chain installation
 Power : 16000 Newtons
 Clamping of very large workpieces

Chain clamping	Ref.
Complete clamping kit	06-040
Comprising : 1 Monobloc short arm with key 1 chain, length 1 m 1 chain attachment block	



Accessories	Ref.
1 meter chain	06-900
chain attachment block	06-910
M 10 fixing	
chain clip	06-905

Chain with rubber pads for clamping fragile workpieces, minimum radius 150 mm. (on request)

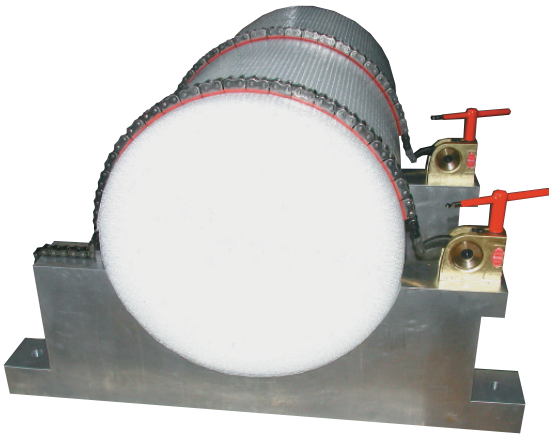

Distribution of clamping force over a large area to prevent workpiece distortion.

Quick chain locking via a compact chain attachment block with M10 mounting.

Powerful and quick clamping with a Monobloc 16000-Newton clamp. Clamp or unclamp the workpiece at the turn of a key - the chain can then clear the workpiece completely.

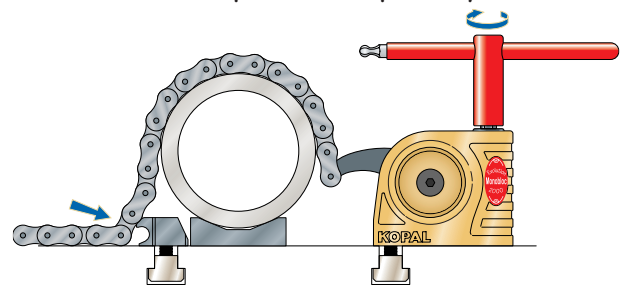

The chain length of 1 metre (longer on request) means you can clamp very large workpieces.

