

Adjustable clamping range  
Lifting and Clamping  
2 interchangeable arms of different shapes  
Same accessories for all the range

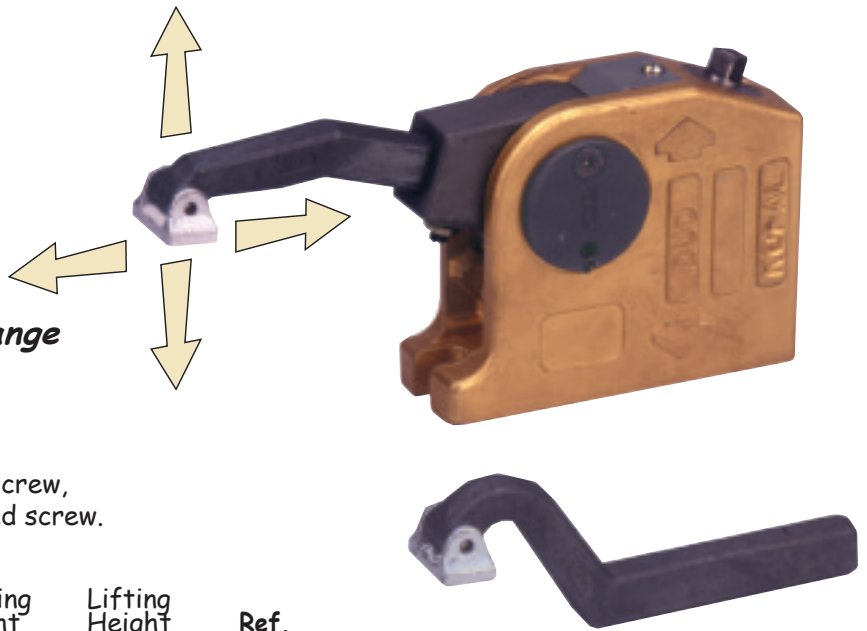

**Clamp**  
With 2 arms, 1 clamping key and 1 clamping screw, aluminium swivel shoe and body, steel arm and screw.

Duo	Clamping Force	Reach	Clamping Height	Lifting Height	Ref.
	11000 N.	46 to 91	0 to 129	4 to 142 mm	21-020
74 mm aluminium riser block					06-050
Coated clamping key, height 58 mm (standard)					06-160

Use :  
T-slot tables  
Modular tables

- 1 Slide the T-nut and screw into the slot
- 2 Position the clamp and clamp it onto the table using the clamping key provided
- 3 Clamp the workpiece using the same key
- 4 Proceed with machining

When the workpiece is unclamped, the Duo remains in position in the slot

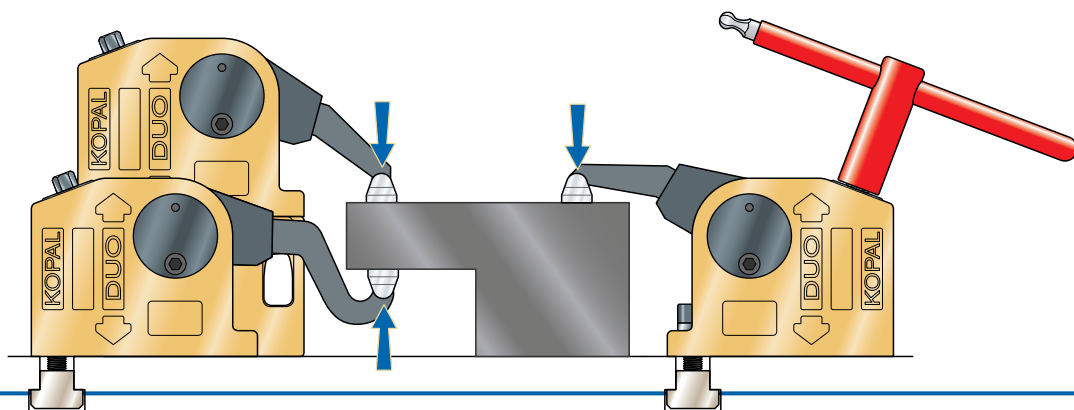
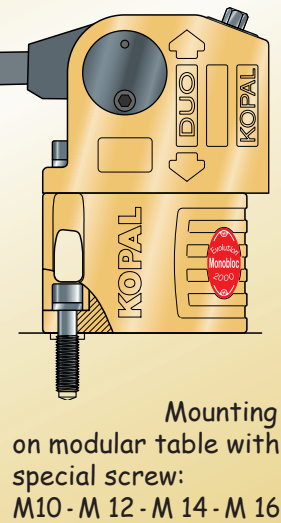
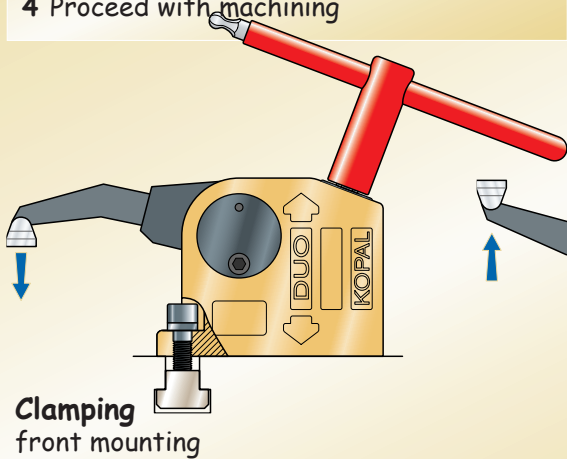

**Mounting**

**Ref.**

M 10 clamping screws	for slot sizes	Ref.
M 10 x 35	12 and 14 mm	06-080
M 10 x 40	16 and 18 mm	06-085
M 10 x 45	20 and 22 mm	06-090

M 10 clamping screws	for tapped holes	Ref.
M 12 x 40	M 12	06-065
M 14 x 45	M 14	06-070
M 16 x 45	M 16	06-075

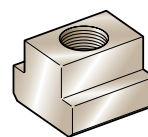
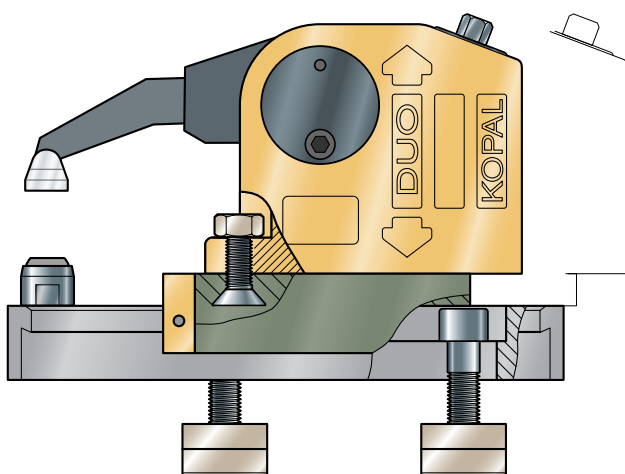
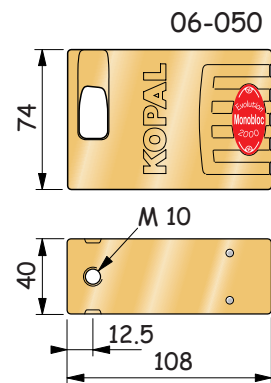
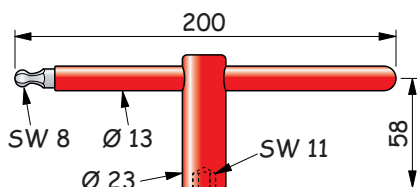
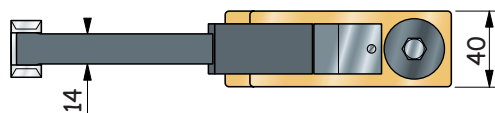
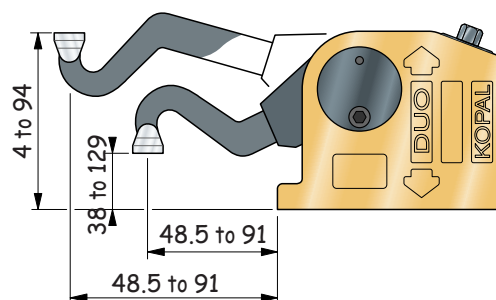
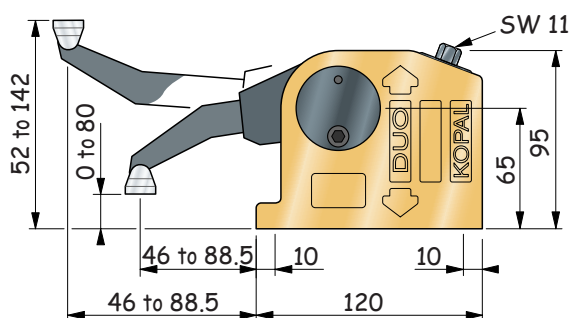

M 10 T-nuts	Slot size	Ref.
	12 mm	90-100
	14 mm	90-105
	16 mm	90-110
	18 mm	90-115
	20 mm	90-120
	22 mm	90-125
	24 mm	90-130
	28 mm	90-135

**Sliding element**  
allows quick retraction of clamp (09-456).

**Accessories**

**Ref.**

Sliding element	09-456
Set of 4 different shaped aluminium swivel shoes	06-150

Accessories available on page 38

