

Standard kit

6500 Newton

Comprising :

- 2 Mini driving clamps 09-110
- 1 Mini fixed clamp / locator 09-150 (with screw and index)

Ref.
09-490

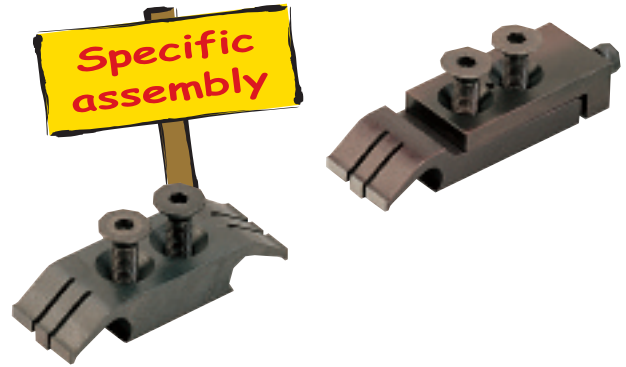

Clamping force : 6500 N
Clamping torque : 6 N.m
Clamping range : 7 mm

Clamping elements

Made of spring steel

(with clamping screw and positioning pin)

Low mini driving clamp

clamping height 2,5 mm
for low workpieces

Standard mini driving clamp

clamping height 6 mm

Ref.

09-111

09-110

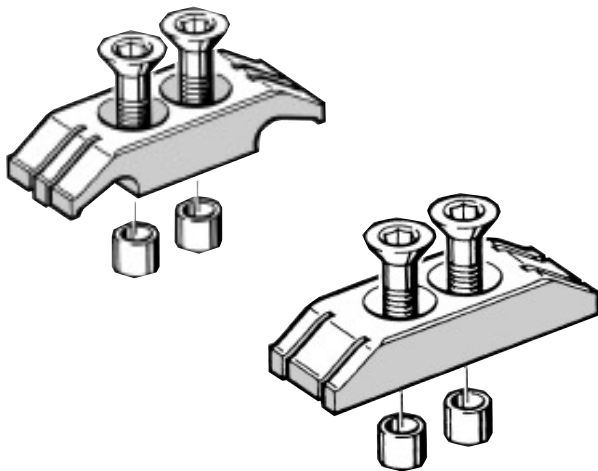
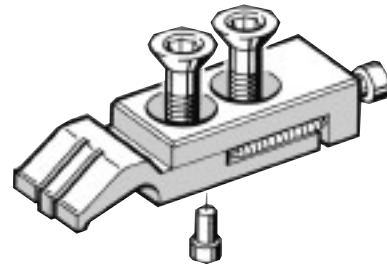

Fixed clamps (Stops)

Ref.

Reversible clamps made of spring steel

for clamping of facing workpieces

(with clamping screw and positioning index)

Low mini reversible clamp/locator

clamping height 2,5 mm
for low workpieces

09-152

Standard mini reversible clamp/locator

clamping height 6 mm

09-150

Double ended mini reversible clamp/locator

clamping height 6 mm

09-151

With two rigid supports - can be used on its own for small workpieces of max. 40mm in width.

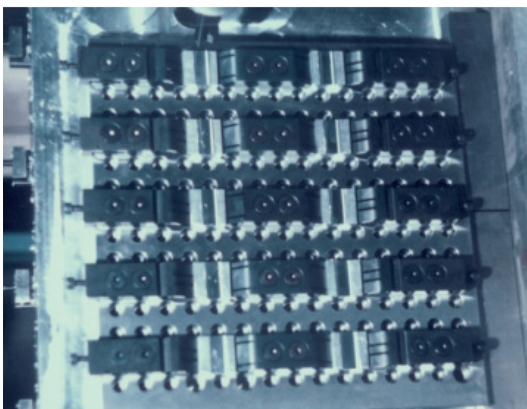

Creation of pallets for clamping 10 workpieces

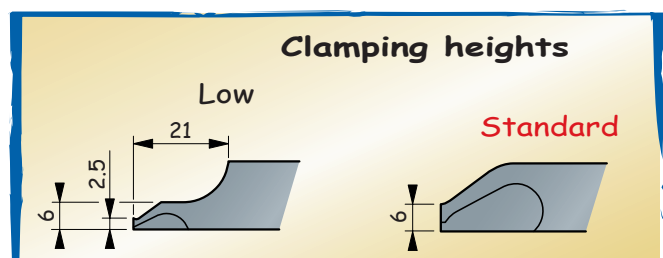

Machining assembly is carried out according to workpiece dimensions.

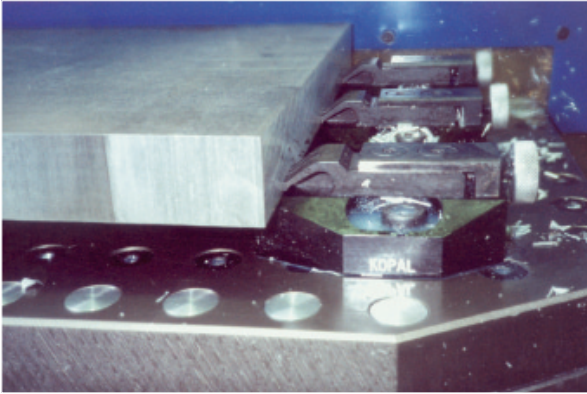

Machining of an aluminium plate with mini driving clamps on special supports

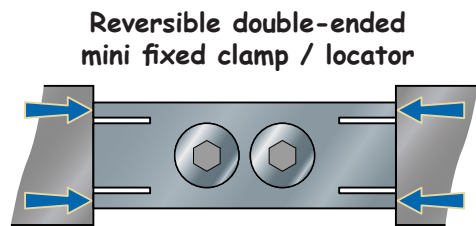
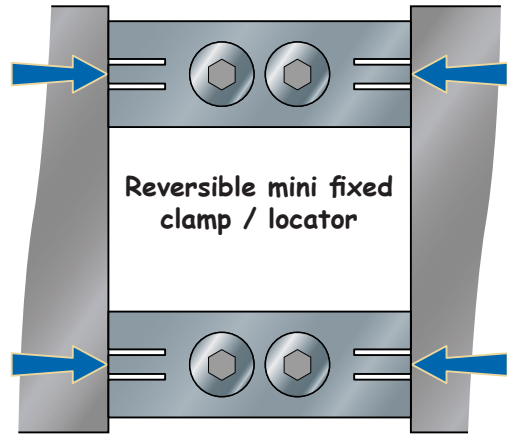

Setting-up

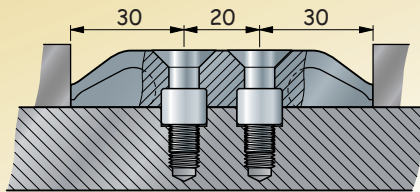

Drilling of :
 2 x M 8 fixing holes, depth 20 mm
 2 x Ø 12 H6 counterborings, depth 6 mm

Drilling of :
 2 x M 8 fixing holes, depth 16 mm
 1 x Ø 6 H6 hole, depth 8 mm

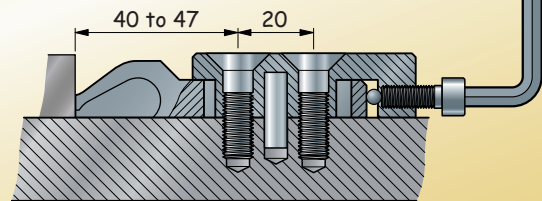

Mini driving clamp

09-110 / 111

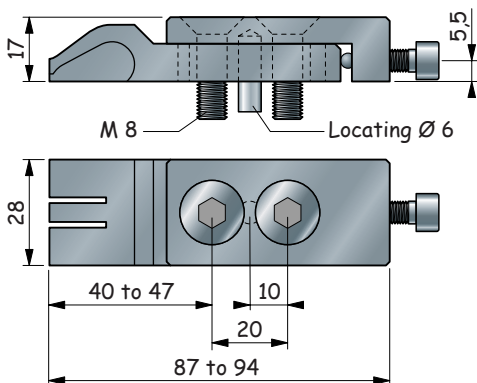

Reversible mini fixed clamp / locator

09-150 / 152

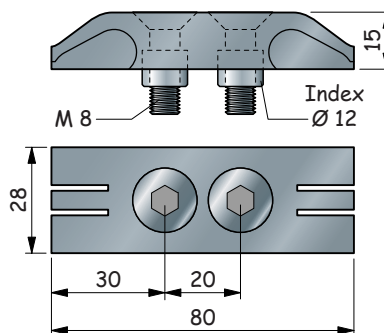

Reversible double-ended mini fixed clamp / locator

09-151

