

KOPAL 12000 NEWTON HORIZONTAL CLAMPING SYSTEM

HYPOBLOC SYSTEM

Ref.
09-010

Complete kit 12000 Newton

Comprising :

- 1 steel 400mm mounting bar 09-015
(mounted with M 12)
- 1 clamping element 09-020
- 1 fixed clamp / locator 09-080
- Clamping screws and clamping key

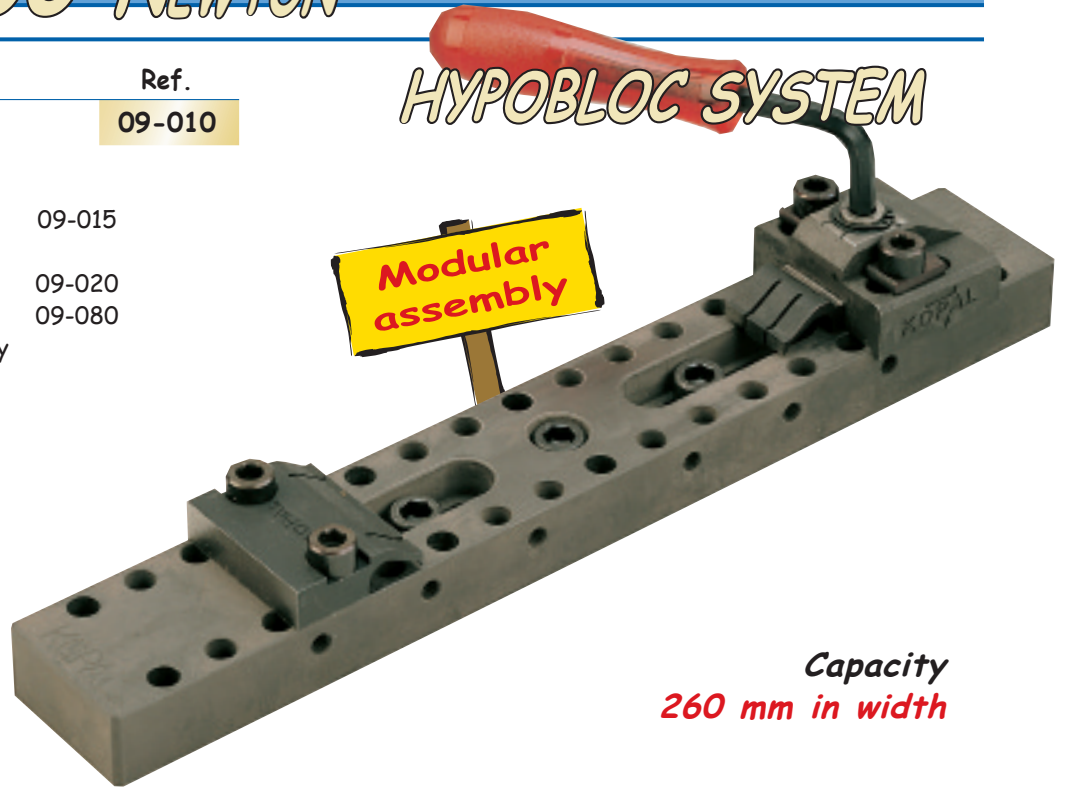

Capacity
260 mm in width

*Is used as a vice
Raises the workpiece to be machined
Precision
Complete surfacing*

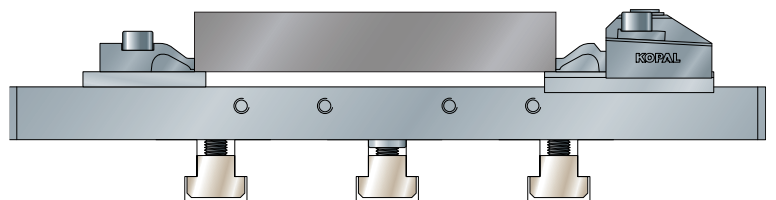
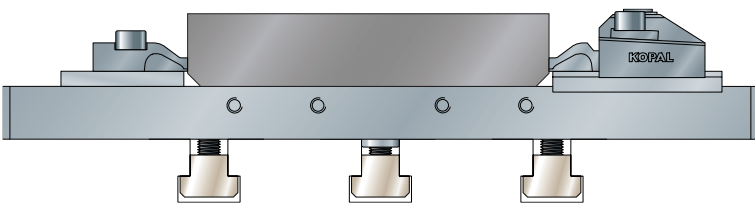
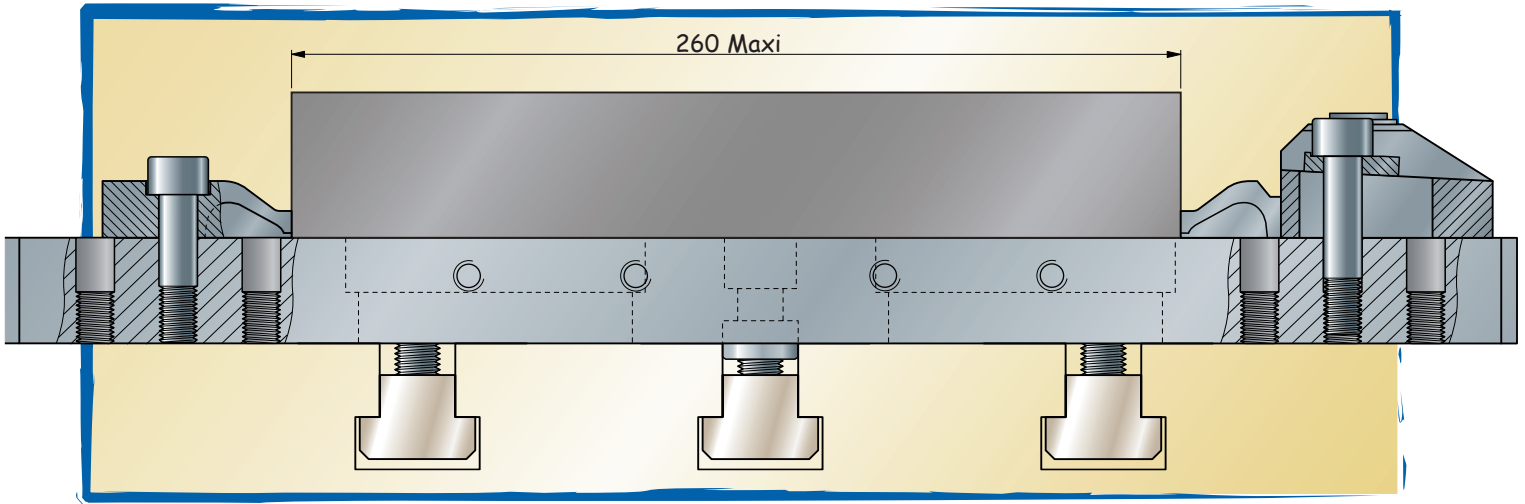
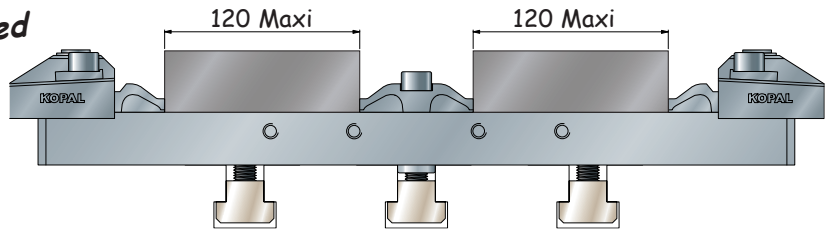

Ref.

09-014

Complete kit
12000 Newton

Comprising :

- 2 multiple supports 09-016
- (mounted with M 12)
- 1 clamping element 09-020
- 1 fixed clamp / locator 09-080
- Clamping screws and clamping key

Modular assembly



Force and Speed



For large workpieces

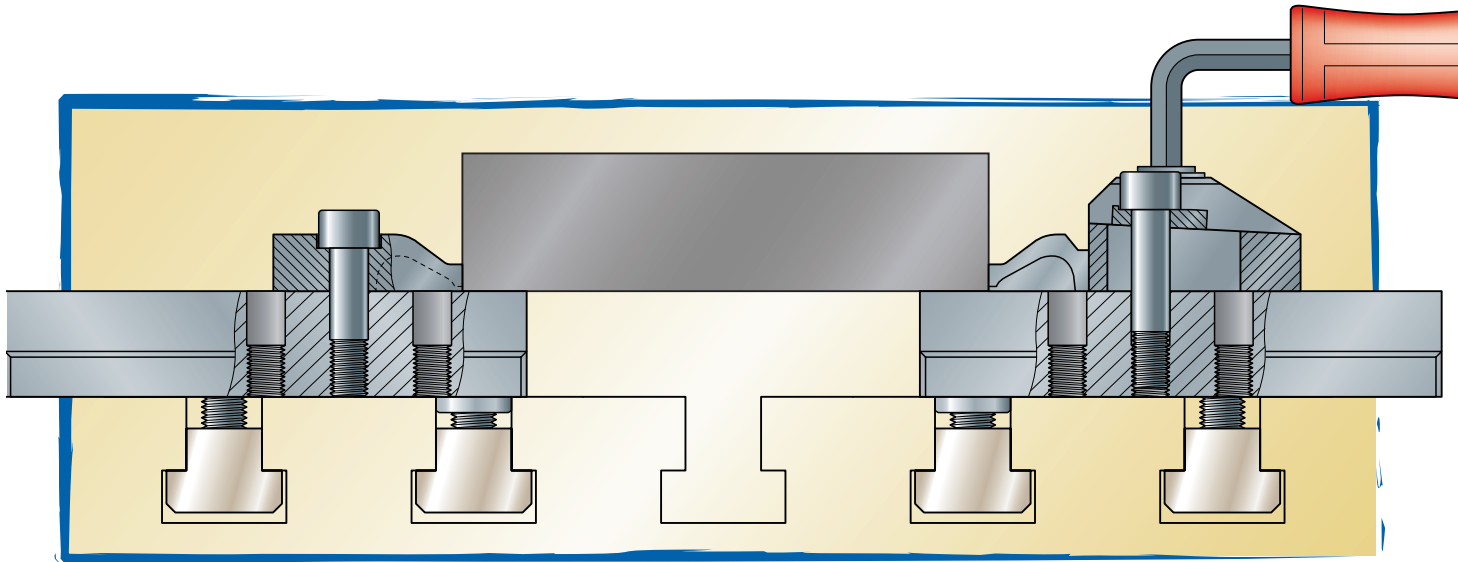

Fast clamping

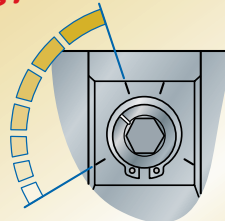

1/4 turn
12000 Newton

Eccentric with 8 mm hexagonal socket
Clamping with left or right turn or left

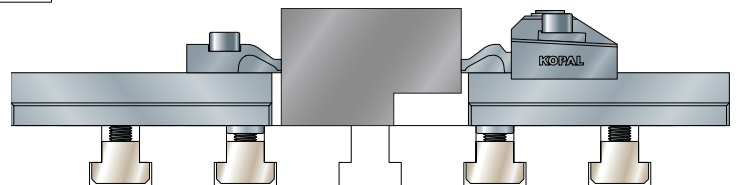
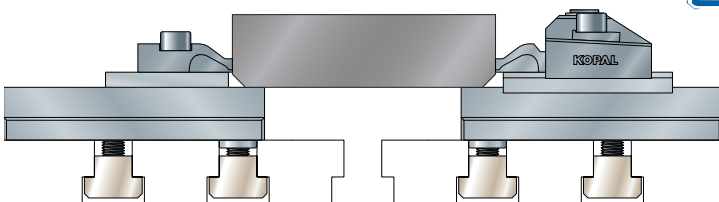

HYPOBLOC SYSTEM

Clamping element

Ref.

Hardened steel body with clamping eccentric and moving spring-steel clamp which pushes down and clamps the workpiece.

(with clamping screws, washers and clamping key)

Clamping element for mounting bar and support

09-020

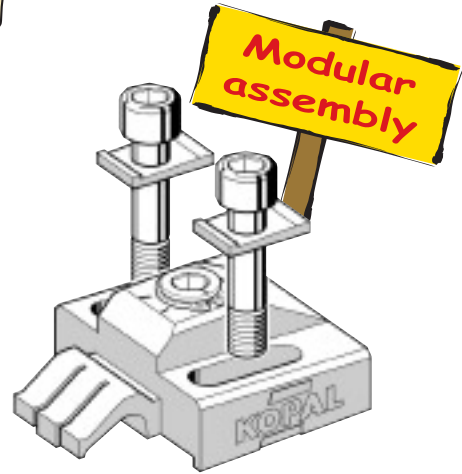

Clamping force : 12000 Newton
 Clamping torque : 70 N.m
 Clamping range : 1,6 mm
 Adjustment : 25 mm

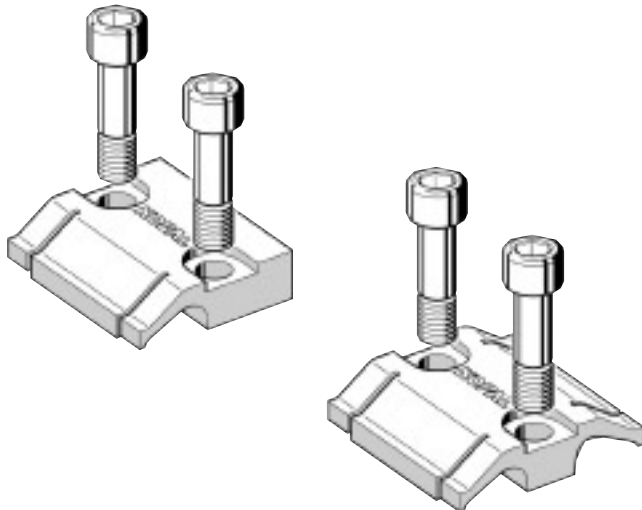

Fixed clamps (Stops)

Ref.

Spring-steel clamp / locator
 (with clamping screws)
 Clamping height 7 mm

Standard clamp / locator

09-080

Double fixed clamp / locator

09-082

For clamping
 2 facing workpieces

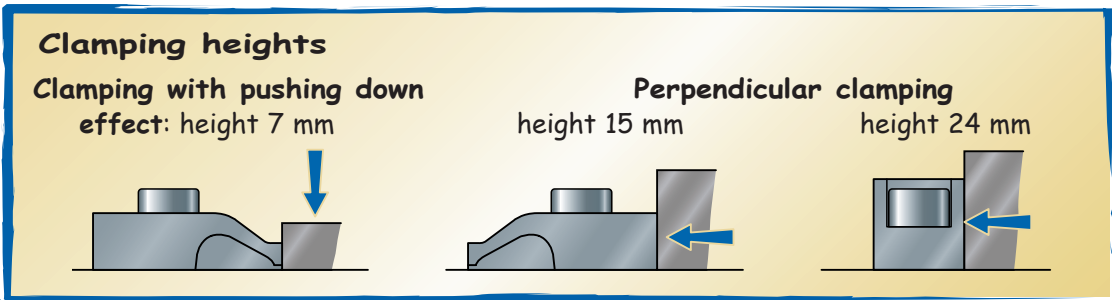

Raised fixed stop

Ref.

Stop made from rectified stainless steel, width 60 mm, height 24 mm, (with clamping screws)

Double fixed stop
 For clamping 1 workpiece
 or 2 facing workpieces

09-084

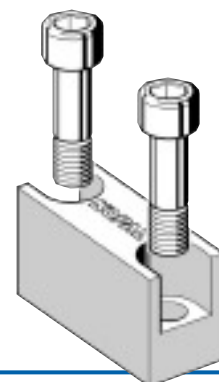

Support (mounting bar)

Hardened steel reference elements
Rectified thickness.

● 2 rows of holes (H6) ensure that clamping components or fixed clamps / locators (stops) are precisely positioned in relation to the centring locator $\varnothing 16 - 28$ mm, located under the lower side of the bar.

400 mm mounting bar 09-015

Mounted with 3 x M 12 screws (provided)
Capacity (width of workpiece) :
1 workpiece 260 mm max
2 workpieces 120mm max

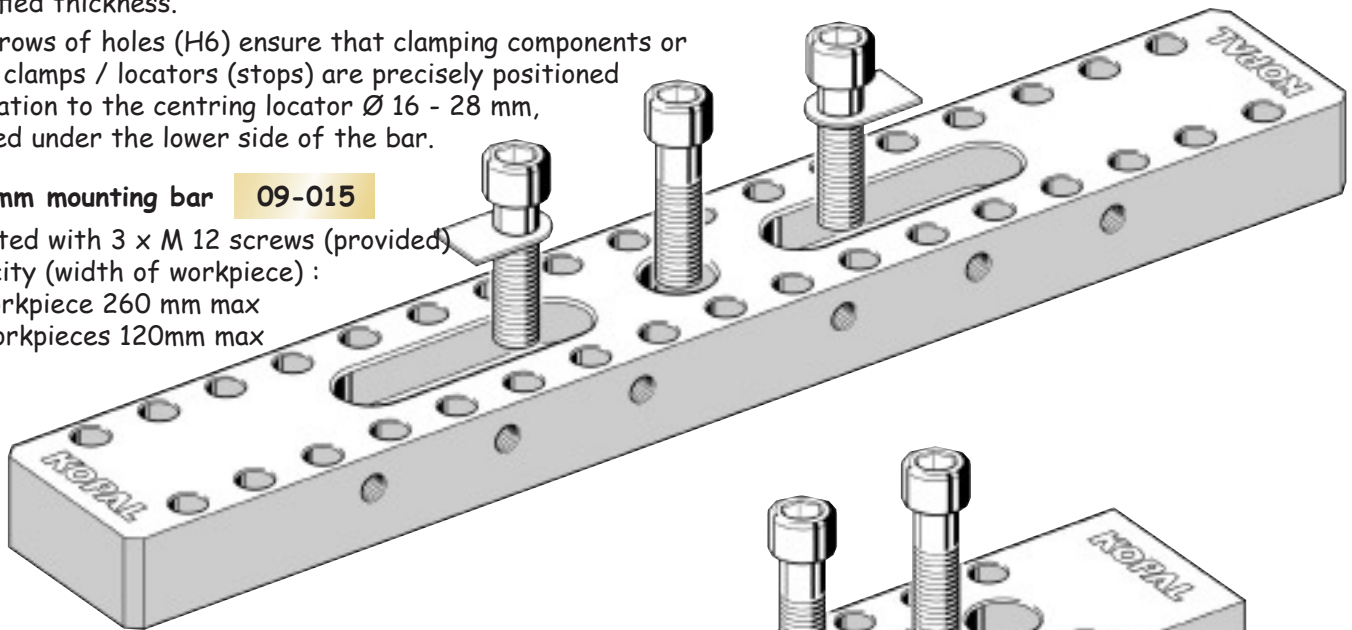

**Multiple support
For large workpieces.**

The workpiece can be clamped on the table or raised by 28 mm.
Mounted with 2 x M 12 screws (provided)

09-016

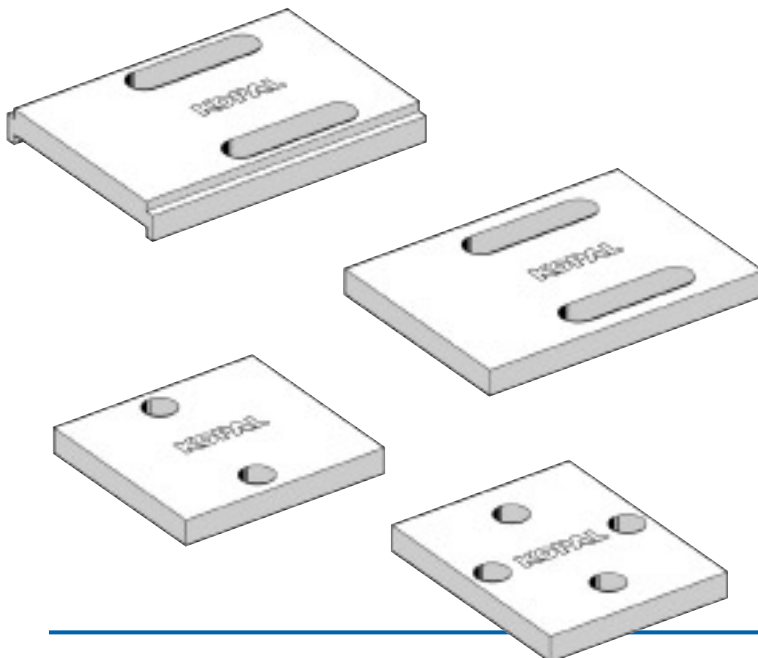
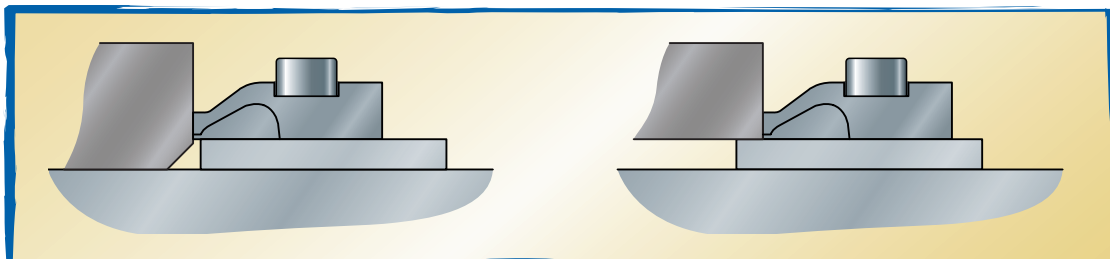
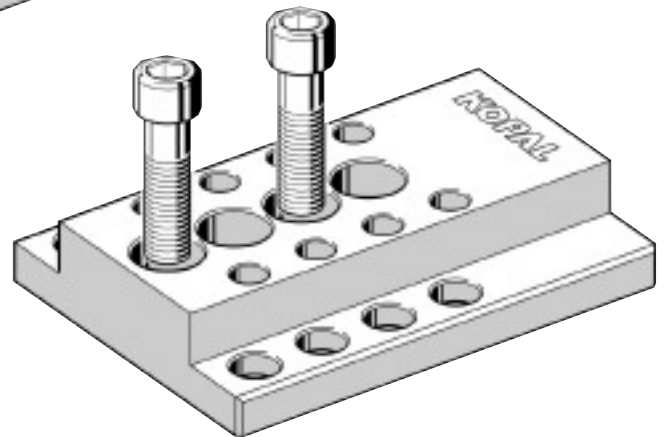

8 mm riser blocks	Ref.
Made from hardened steel with rectified thickness, they raise the clamping height or the workpiece by 8 mm.	
Riser block for clamping element on mounting bar Use 55 mm screws (09-878).	09-866
Riser block for clamping element on special machining set-up Use 55 mm screws (09-878).	09-867
Riser block for standard fixed clamp Use 47 mm screws (09-876).	09-868
Riser block for double-ended fixed clamp Use 47 mm screws (09-876).	09-870

HYPOBLOC SYSTEM

Rectified centring screws Ref.
 Ø 10.2 - M 10 screws for mounting clamping elements and stops.

39 mm screw Ref. **09-874**
 For mounting single fixed clamps.

47 mm screw Ref. **09-876**
 For mounting clamping elements and fixed clamps with riser blocks.

55 mm screw Ref. **09-878**
 For mounting clamping elements with riser block.

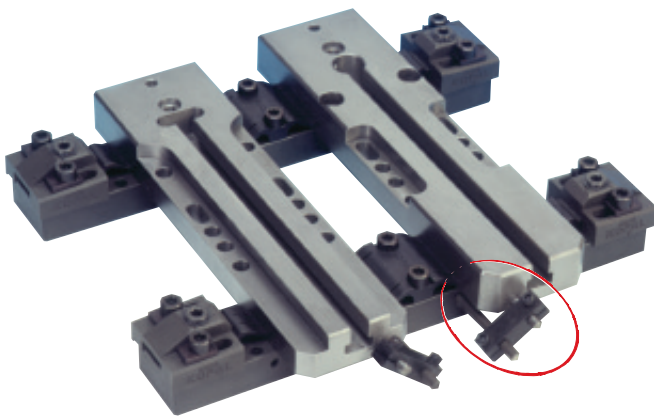
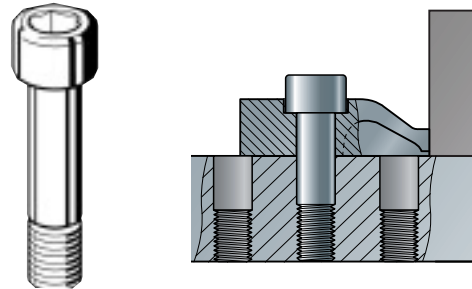

Lateral stop Ref.
 The lateral stop is positioned in 6 x M 8 points on the side of the mounting bar. It is adjustable in height and length. 8 mm fulcrum rod.

09-086

Rigid Compact

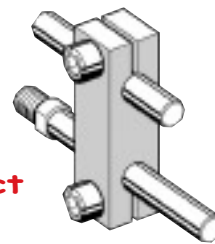

Locators Ref.
 Made from hardened rectified steel with M 14 internal screw thread for extraction.
 For slot size or diameter:

- | | |
|-------|--------|
| 16 mm | 09-886 |
| 18 mm | 09-888 |
| 20 mm | 09-890 |
| 22 mm | 09-892 |
| 24 mm | 09-894 |
| 26 mm | 09-896 |

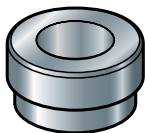

These locators enable quick and precise alignment of mounting bars and supports.

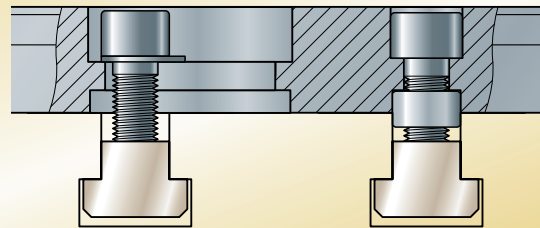

T-nuts for T-slots M 12

Ref.	Ref.	Ref.	Ref.	Ref.	Ref.	Ref.
14 mm	16 mm	18 mm	20 mm	22 mm	24 mm	28 mm
90-150	90-155	90-160	90-165	90-170	90-175	90-180

