

Standard M10 kit ref. 09-495
10000 Newton

- Comprising :
- 1 x M 10 driving clamp 09-065
 - 1 standard moving clamp / locator 09-610
 - 1 standard fixed M 10 clamp / locator 09-140
 - Clamping screw and clamping key



Clamping force : 10000 Newton
Clamping torque : 12 N.m
Clamping range : 20 mm

Standard M12 kit Ref. 09-496
10000 Newton

- Comprising :
- 1 x M 12 driving clamp 09-068
 - 1 standard moving clamp / locator 09-610
 - 1 standard fixed M 12 clamp / locator 09-141
 - Clamping screw and clamping key

Direct clamping on the table
Quick assembly
Complete surfacing
Multiple clamping heights

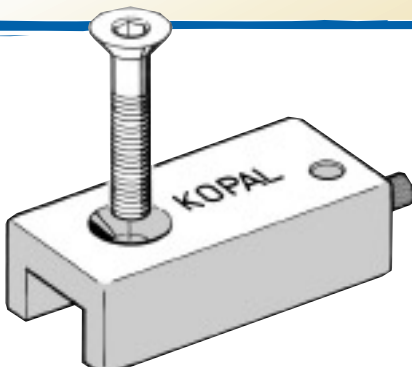
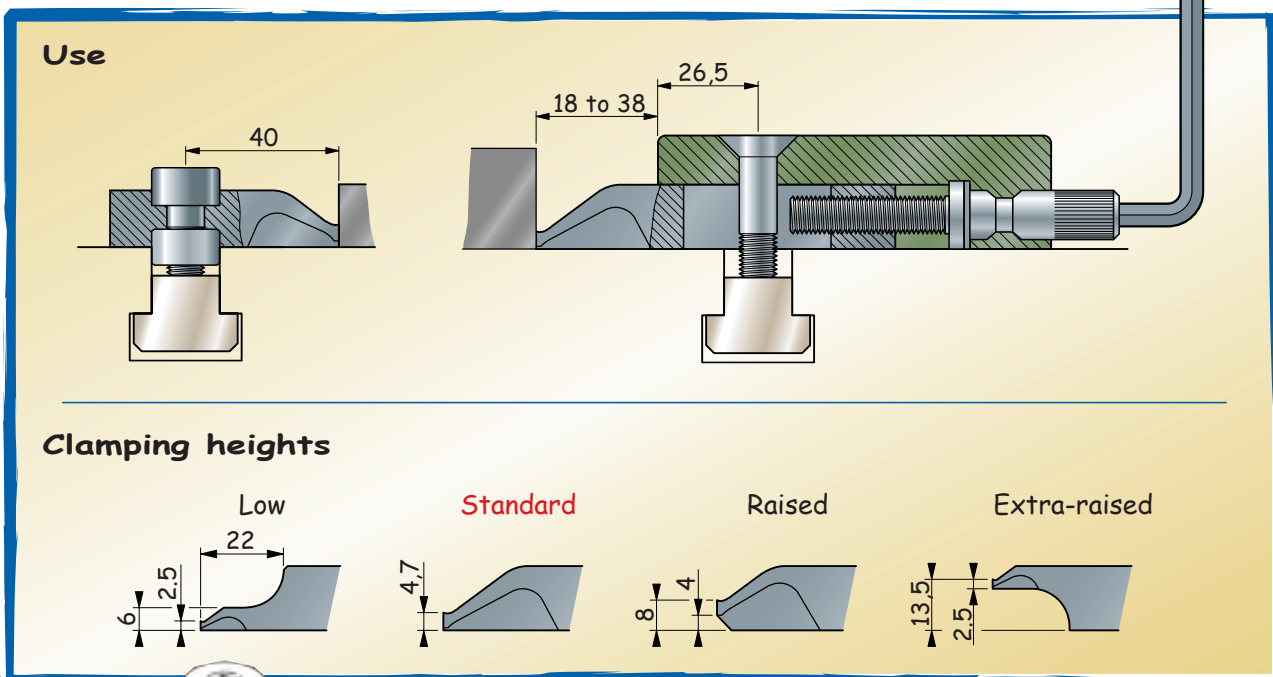

Clamp body Ref.
Aluminium body for moving clamps / locators
(with pressure screw and clamping screw)

Table-mounted driving clamp 09-065
Mounting with 1 x M 10 screw

Table-mounted driving clamp 09-068
Mounting with 1 x M 12 screw

Moving clamps / locators for clamping body

Clamp made of spring steel

(works with the body pressure screw)

Low moving clamp / locator
clamping height 2.5 mm

09-615

Standard moving clamp / locator
clamping height 4.7 mm

09-610

Raised moving clamp / locator
clamping height 8 mm

09-620

Extra-raised moving clamp / locator
clamping height 13.5 mm

09-625

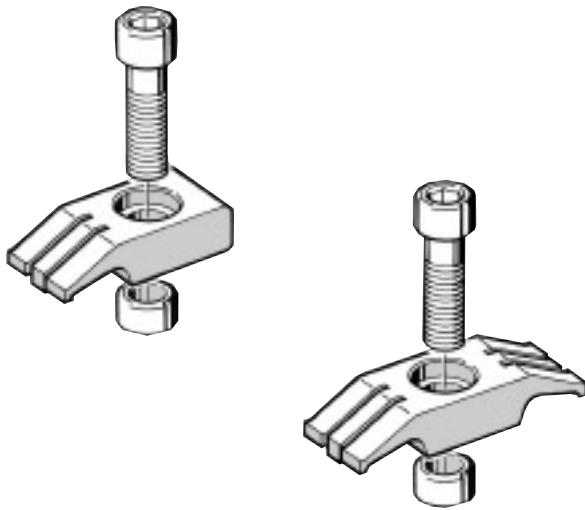
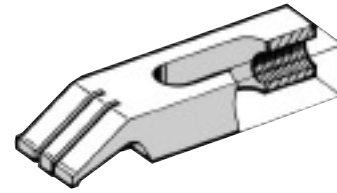

Table-mounted clamps / locators (stops)

Clamp made of spring steel

(with clamping screw and Ø 18 mm locator)

Low clamp / locator clamping height 2.5 mm

Mounted with M 10

09-143

Mounted with M 12

09-144

Standard clamp / locator clamping height 6 mm

Mounted with M 10

09-140

Mounted with M 12

09-141

Extra-raised clamp / locator clamping height 13.5 mm

Mounted with M 10

09-142

Standard double ended clamp clamping height 6 mm
for clamping two facing workpieces

Mounted with M 10

09-145

Mounted with M 12

09-147

Table-mounted clamps / locators

09-140 / 141 / 142 / 143 / 144

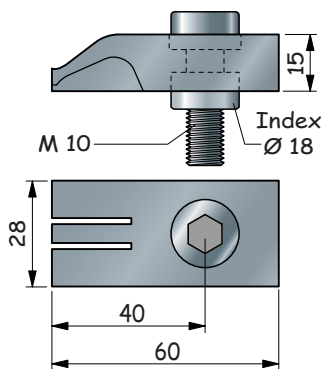

09-145 / 147

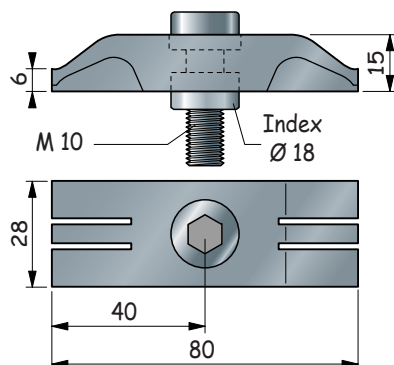

Table-mounted clamps / locators

When the clamps are used lengthways along the slots, the use of anti-sliding T-nuts is recommended in order to resist the force of pressure exerted by the clamping element.

See following page!

Moving clamps / locators

09-610 / 615 / 620 / 625

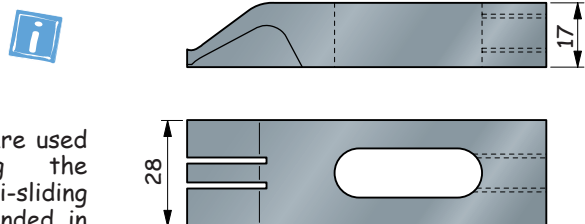

Table driving clamp 09-065 / 068

