

The Kastor is a portable machine for chamfering very large workpieces or for use on a workbench for small workpieces. With its 450-W motor, it can perform chamfers of 0 to 2.5 mm on a flat surface on all types of materials.

Two steel base plates ensure that the workpieces to be chamfered are correctly guided and simplify the adjustment of the chamfer value.

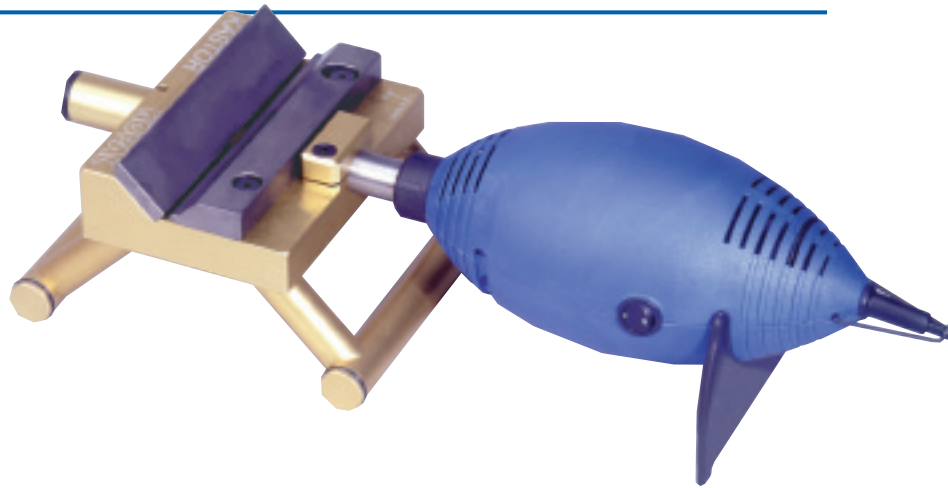

*Portable or workbench use
Very simple adjustment
Long cutter service-life*

An indispensable addition to your machining centre.

Chamfer in concurrent operation time!

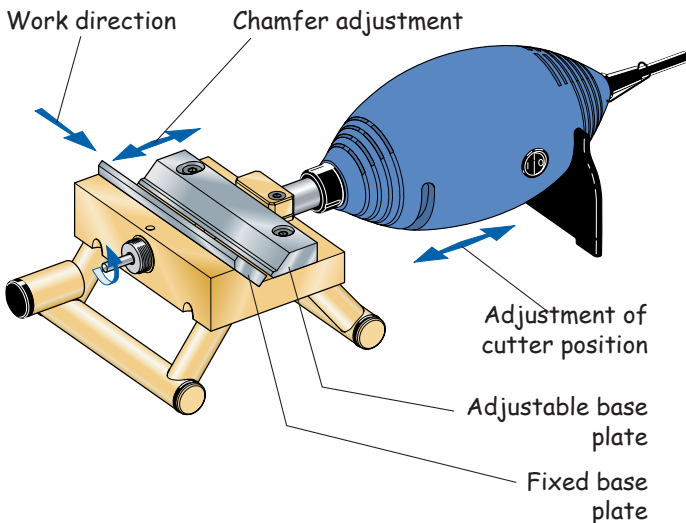

KASTOR

Ref.

CLASSIC

AZ-011

TRONIC

AZ-014

Capacity on flat surface : 0 to 2.5 mm at 45°
Rotation speed : 2 000 - 22 000 rpm
Carbide cutter : Ø 6 mm
Motor : 450 W - 230 Volts AC
Weight : 3.8 kg

Cutter

AZ-920



Ø 6 mm carbide cutter, length 115mm, middle cutter with 26 mm right-handed twist.

KASTOR CLASSIC AZ-011

Electronic variable-speed motor with foot pedal.

The foot pedal is equipped with an adjustable 5-position speed limiter and a manual variable-speed control button

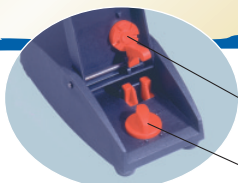
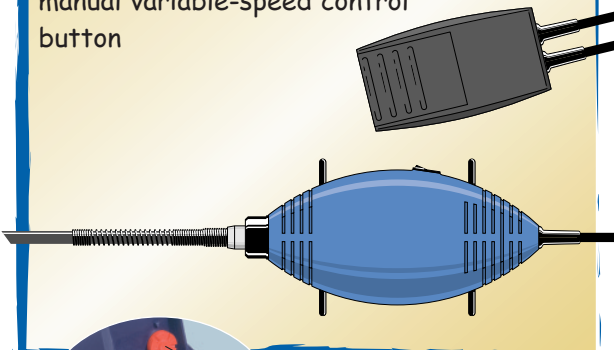

Foot-controlled variable-speed limiter
Manual variable-speed control button

KASTOR TRONIC AZ-014

Motor with electronic speed regulator, with manual control via indexed adjustment wheel.

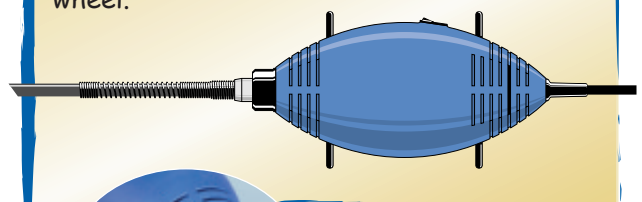

variator adjustment wheel

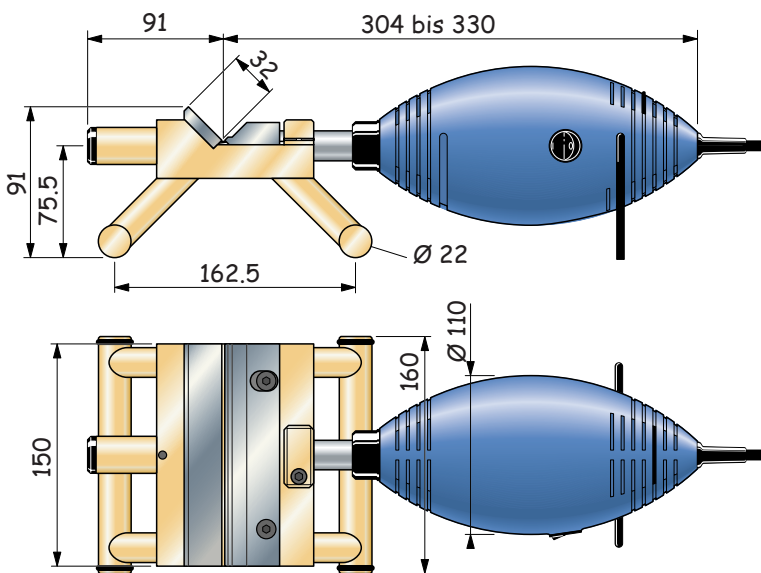
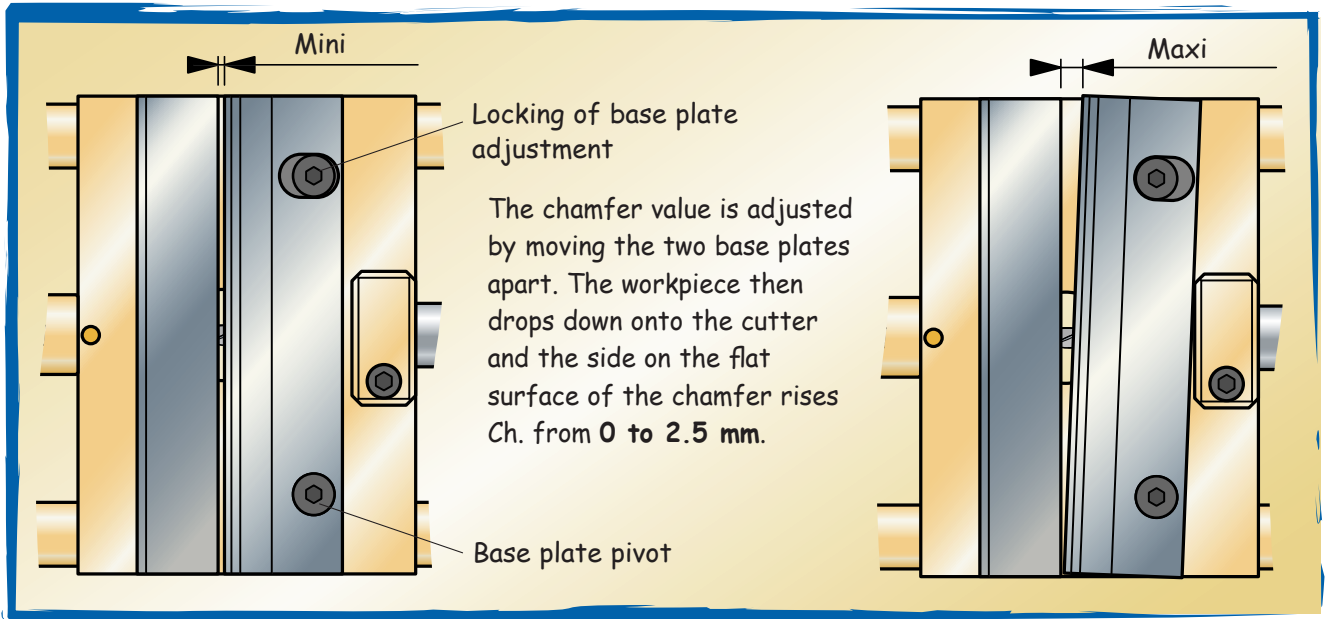

The Ø 6 mm carbide cutter, cut only in its mid-section, is precision guided between two roller bearings.

**Quality
Speed**

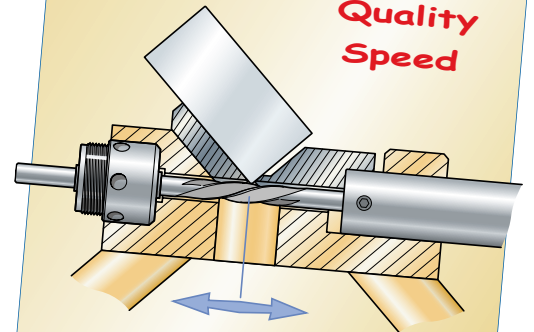

The cutter's useful sharpening length allows numerous cutting positions just by moving the cutter-drive spindle unit.

Stable and rigid on a workbench

1 single machine for 2 applications

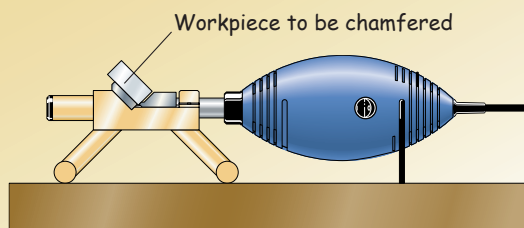

**Machine for workbench
and
portable machine**



Practical and easy to handle