

i The outer HSS blades are sharpened with cutting angles of : 0° - 14° - 20° and 25°, to be specified on ordering.

Chamfers all tube ends and cylindrical or polygonal bar ends

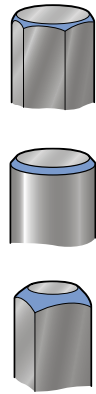
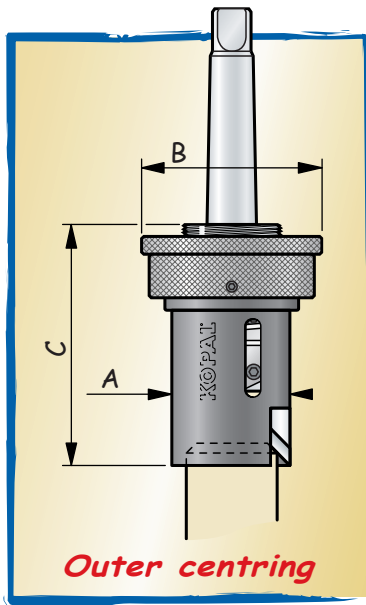

Model	A	B	C 90° / 60°
2-18	Ø 18	Ø 26	54
2-36	Ø 42	Ø 65	85 / 105
10-46	Ø 48	Ø 65	85 / 109
20-60	Ø 60	Ø 70	85 / 109
40-80	Ø 80	Ø 90	95 / 118
60-100	Ø 100	Ø 110	107
80-120	Ø 120	Ø 130	110

Blades

The small 2-18 models have 1 cutting edge.
All the other models have 2 cutting edges

Ingeniously reversible

Chamfer diameter	Model	Attachment	Angle of the chamfer tip	
			60° Ref.	90° Ref.
2 to 17	2-18	cyl. Ø 10 CM1	02-020	02-010
			02-025	02-015
4 to 37	2-36	cyl. Ø 10/Ø 16 CM2	02-055	02-035
			02-050	02-030
9 to 45	10-46	cyl. Ø 10/Ø 16 CM2	02-110	02-095
			02-105	02-090
21 to 57	20-60	CM2	02-140	02-135
40 to 77	40-80	CM2	02-155	02-150
		CM3	02-156	02-151
60 to 97	60-100	CM3		02-166
80 to 117	80-120	CM3		02-181

